

## 50W Floodlight Data Sheet

**MODEL: SP50FL**



### 50W Floodlight

7000 Lumens

50 000 Hours L70 rated life

Bridgelux LED 3030

Meanwell ELG-100 Driver

Fully Adjustable

IP65

Made in South Africa



The 50W LED Modular Flood Light is a safe, reliable and affordable replacement to the older generation power thirsty flood lights. The SP50FL carries a 5 year warranty and utilises only the best quality LED components currently available.

The SP50FL IP65 Modular floodlight is resilient and uncompromising in its performance. It offers unrivalled light quality, superior colour rendition and sustained energy savings over the 50 000 hour life span also accompanied with a 5 year warranty.

## Applications

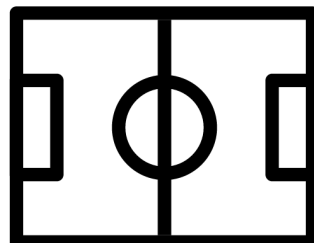

## Product information

An industry leading versatile Modular LED solution that guarantees the best quality of light presently available in the flood light market.

Application: The SP50FL Modular LED meets a variety of lighting needs across three different applications: architectural, area lighting and signage.

## Structures and materials

**Housing:** Laser cut steel housing electro-statically sprayed with a polyester powder paint finish, following anti-corrosion priming, and oven cured at 180°C.

**Standard colour:** silver & black.

Conforms to 2G vibration standards.

## Electrical and gear compartment

Mean Well HLG-60 driver.  
Isolated from the environment.

**Protection degree:** IP67.

**Nominal line voltage:** 100-277V 50-60Hz.  
PF>0.9.

**Class:** I.

**Cable:** silicon rubber cable for power input.  
Fasten with screw in the cable gland.

**Temperature:** -30°C to +45°C

## Optics

Optical Diffuser: Silicone sealed lens allowing IP65.

Light uniformity: The advanced LED optic transmission lens system maximises the utilization of light onto the target surface area which improves the dispersion and uniformity of light.

Choice of optics: Beam angles available from 90° to 120°.

• Narrow Spot NEMA (1x1) • Medium Flood NEMA (5x5) • Wide Flood NEMA (6x5)

Colour temperature: The EL100W LED floodlight is available in 6000K providing a high lumen output which is free from blue light hazard. While maintaining a high CRI and ANSI binning within 5 Step Macadam.

## LED Maintenance

70% lumen maintenance at 50,000 hours.  
Rated at LM70

## Installation

Wall mounting bracket which is fully adjustable and easy to install.

# Specifications & Data

<b>Model</b>	<b>SP50FL</b>
<b>Wattage</b>	<b>50W</b>
<b>Luminous Flux</b>	<b>7000lm</b>
<b>Luminous Efficacy</b>	<b>140lm/w</b>
<b>Colour Rendering Index</b>	<b>80</b>
<b>Correlated Colour Temperature</b>	<b>6000K</b>
<b>Ingress Protection Rating</b>	<b>IP65</b>
<b>Beam Angle</b>	<b>90°</b>
<b>Input Voltage</b>	<b>100-277V AC</b>
<b>Power Factor</b>	<b>0.95</b>
<b>Housing</b>	<b>Laser Cut Steel &amp; Aluminium</b>
<b>Lens</b>	<b>Clear Plastic Optic Diffuser</b>
<b>Mounting</b>	<b>Adjustable Steel Bracket</b>
<b>Total Harmonic Distortion</b>	<b>20%</b>
<b>Operating Temperature</b>	<b>-20C + 50C</b>
<b>Environment</b>	<b>Outdoor &amp; Indoor</b>
<b>Life Span</b>	<b>50000 hours LM70</b>
<b>Warranty</b>	<b>5 years</b>

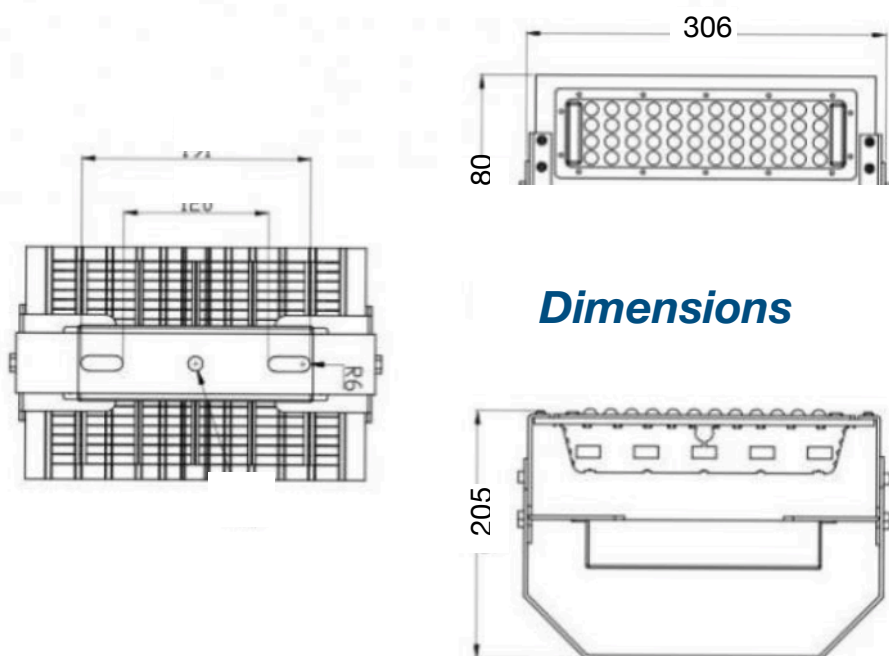

# Core Components

## LED High-bay & FloodLight

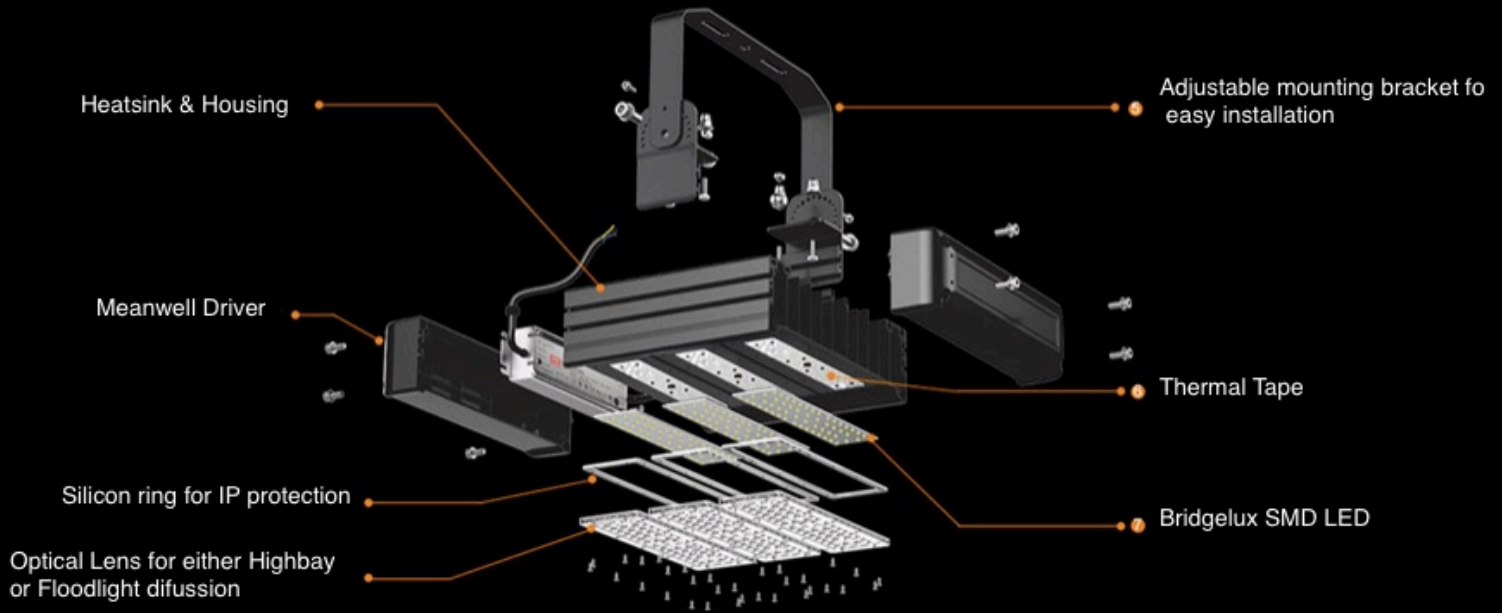

The HLG-60 series is a 60W AC/DC LED driver featuring dual mode constant current and constant voltage output. Operating at 90.5% efficiency, the driver is able to operate in environments ranging in temperatures from  $-40^{\circ}\text{C}$  to  $+90^{\circ}\text{C}$ . Its high IP67 ingress protection rating allows it to operate comfortably in outdoor and indoor applications. The reliable Meanwell driver comfortably drives the flood light to achieving the rated 50 000 hour life span.



The Bridgelux SMD 3030 offers exceptional performance in a compact LED package. This mid power LED is hot-colour targeted which ensures that the LEDs fall within their specified colour bin at the typical application conditions of  $85^{\circ}\text{C}$ . With its broad lumen coverage and wide range of CCT options, the SMD 3030 provides unparalleled design-in flexibility for indoor and outdoor lighting applications. Its high lux capability reduces the number of LEDs and enables industry leading system level lumen per Rand. The SMD 3030 is ideal as a drop in replacement for emitters with an industry standard 3.0mm x 3.0mm footprint.